

Mini review

Aspects of non-classical organolanthanide chemistry

M. Cristina Cassani, Yurii K. Gun'ko, Peter B. Hitchcock, Alexander G. Hulkes,
Alexei V. Khvostov, Michael F. Lappert*, Andrey V. Protchenko

The Chemistry Laboratory, School of Chemistry, Physics and Environmental Science, University of Sussex, Brighton, East Sussex BN1 9QJ, UK

Received 29 October 2001; accepted 25 November 2001

Abstract

This paper provides a survey of our studies on: (i) subvalent compounds of lanthanum and early 4f elements; (ii) cationic mononuclear samarium(II) and ytterbium(II) organic complexes; (iii) low valent samarium and ytterbium β -diketiminates; and (iv) mononuclear cerium(IV) amides and a mixed valence trinuclear Ce(IV)/Ce(III) cluster. A brief introductory section points to our earlier (1973–1995) studies on organo-4f-element chemistry. © 2002 Elsevier Science B.V. All rights reserved.

Keywords: Lanthanide complexes; Cyclopentadienyls; Amides; β -Diketiminates; *tert*-Butoxides

1. Introduction

This survey will focus on four areas of organolanthanide chemistry which we regard as ‘non-classical’ (the ‘classical’ organo-Ln(II) compounds are neutral or anionic Sm, Eu or Yb derivatives). These are: (i) subvalent compounds of lanthanum and the early 4f elements; (ii) cationic mononuclear samarium(II) and ytterbium(II) organic complexes; (iii) low valent samarium and ytterbium β -diketiminates; and (iv) mononuclear cerium(IV) amides and a mixed valence trinuclear Ce(IV)/Ce(III) cluster. These studies date from 1995.

Our earlier work on organolanthanide chemistry (which we take to encompass Sc, Y, La, as well as the 4f elements, collectively abbreviated as Ln) began in the early 1970s (for the first publication, see Ref. [1]) and was carried out by (in chronological order): (a) post-doctoral fellows R. Pearce, G.K. Barker, A. Singh, G.A. Lawless and X. Cai; and (b) graduate students J. Holton (1976), P.I.W. Yarrow (1979), R.G. Smith (1987), S. Prashar (1991), S.R. Holmes (1992), S. Tian (1994) and J.R. van den Hende (1995); the dates in

parentheses refer to their DPhil (Sussex) Theses. Some highlights of their contributions relate to a number of ‘firsts’ (R = SiMe₃): (a) *Ln(III) alkyls*: the neutral [Ln(CH₂R)₃(thf)₂] (Ln = Sc, Y) [1], [Ln(CH₂R)₃] (Ln = La, Sm) [2], and the heterobinuclear [Li(thf)₄][Ln(CH₂R)₃Cl] and [Li(thf)₄][Ln(CH₂R)₄] (Ln = Er, Yb) [3] and [Ln(CH₂R)₃(μ -X)Li(pmdeta)] (Ln = La, Sm; X = Cl, Me) [4]; (b) *Ln(III) bridging alkyls*: [LnCp₂(μ -Me)₂AlMe₂] and [LnCp₂(μ -Me)]₂ [5]; (c) *Ln(II) alkyls and cyclopentadienyls*: [Yb(CR₃)(μ -OEt)(OEt₂)₂] [6a] (see also Ref. [7]), [Yb(CH₂R)₂(OEt₂)₂] [6b] and [YbCp₂(thf)₂] [8] (see also Ref. [9]); (d) *Ln(III) 1,3-bis(trimethylsilyl)cyclopentadienyls*: [PrCp₂(μ -Cl)]₂ [10], [NdCp₂(μ -Cl)₂Li(thf)₂] [11], and [AsPh₄][NdCp₂-Cl₂] [12]; (e) *Ln(III) mononuclear aryloxides and thio-lates*: [Ln(OArMe)₃] (Ln = Sc, Y) [13] and [Sm(SAr^t-Bu)₃] [14] (OArMe=OC₆H₂Bu₂-2,6-Me-4; SAR^tBu=C₆H₂Bu₃-2,4,6); (f) *Ln(II) alkoxides and aryloxides*: [Yb(OC^tBu)₃(thf)₂] [15] and [Yb(OArMe)₂(thf)₂] [16]; (g) *homoleptic Ln(II) cyclopentadienyls*: [LnCp₂] _{∞} (Ln = Eu, Yb) [17]; (h) *mononuclear Ln(III) β -diketiminates (LL) and 1-azaallyls (LL')*: [Ce(LL)(CHR₂)₂] and [Nd(LL)₂Cl] [18] (see also Ref. [19]) and [Sm(LL')₂-I(thf)] [20]; (i) observation of ¹⁷¹Yb-NMR spectra [21]; and (j) silylene complexes [LnCp₃{Si(NCH₂Bu)₂C₆H₄-1,2}] (Ln = Y, Yb) [22].

* Corresponding author. Tel.: +44-1273-678316; fax: +44-1273-677196.

E-mail address: m.f.lappert@sussex.ac.uk (M.F. Lappert).

2. Subvalent compounds of lanthanum and the early 4f elements

2.1. Introduction

Thermally stable Ln(0) complexes, such as $[\text{Ln}(\eta^6\text{-C}_6\text{H}_3\text{Bu}_3\text{-1,3,5})_2]$ (Ln = Sc, Y, Nd, Gd, Tb, Dy, Ho, Er, Lu) have been made by cocondensation of the metal vapour and the arene by Cloke and his coworkers (cf. Ref. [23]). In the case of the scandium experiment, a coproduct was the Sc(II) compound **A**, which was obtained in admixture with $[\text{Sc}(\eta^6\text{-C}_6\text{H}_3\text{Bu}_3\text{-1,3,5})_2]$ and was identified by EPR and UV–Vis spectroscopy [24]. The other Ln(0) complexes to have been made were $[\text{Ln}(\eta^6\text{-1-PC}_5\text{H}_2\text{Bu}_3\text{-1,3,5})_2]$ (Ln = Sc, Y, Ho) by a similar metal vapour synthesis procedure [25]. A second scandium(II) compound **B**, from scandium metal vapour and 'BuCP, was obtained [Eq. (1)], together with the only scandium(I) complex, the crystallographically characterised compound **C** [26], thus far reported; compound **B** was established by a combination of EPR and UV–Vis spectroscopy and magnetic measurements [27].

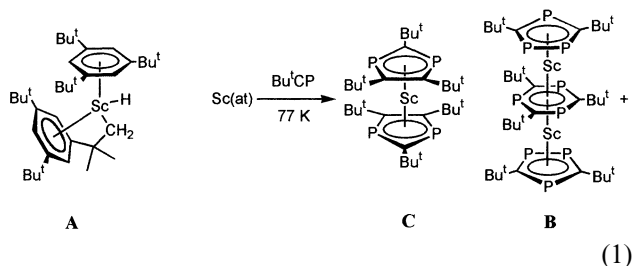

Claims have been made for organo-cerium(II) and -neodymium(II) complexes of formulae $[\text{K}(\text{monoglyme})_2][\text{Ce}(\text{C}_8\text{H}_8)_2]$ [28] and $[\text{K}(\text{thf})_n][\text{NdCp}_2^*\text{Cl}_2]$ [29], but the evidence for each was rather circumstantial. A number of non-classical mononuclear Ln(II) iodides

Table 1

$E_{1/2}$ (V) values, relative to the $[\text{FeCp}_2]^+ / [\text{FeCp}_2]$ couple, for $[\text{LnCp}_3^x]$ compounds in thf at 25 °C, with $[\text{NBu}_4][\text{PF}_6]$ (0.2 mol dm⁻³) as supporting electrolyte, at variable scan rates (10–500 mV s⁻¹), at a vitreous carbon working electrode

Compound	$E_{1/2}$ (V)	References
$[\text{LaCp}_3^x]$	–2.80	[42]
$[\text{LaCp}_3^y]$	–3.10	[42]
$[\text{CeCp}_3^x]$	–2.78	[43]
$[\text{PrCp}_3^x]$	–2.74	[43]

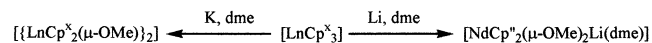

1a Cp^x = Cpⁿ and
Ln = Ce or Nd

1b Cp^x = Cp^h and Ln = Ce

2

Scheme 1. The C–O bond cleavage of dme by $[\text{LnCp}_3^x]/(\text{K or Li})$ [44].

have recently been prepared, of formulae $[\text{LnI}_2(\text{dme})_3]$ (Ln = Tm [30], Nd [31], Dy [31,32], $[\text{LnI}_2(\text{thf})_5]$ (Ln = Nd, Dy) [31,33] and $[\text{TmI}_2(\text{dme})_2(\text{thf})]$ [33]; X-ray data are available for each except $[\text{NdI}_2(\text{dme})_3]$. Efforts have been made to displace one or more iodide ligands by hydrocarbyl groups, but these have inevitably led to Ln(III) products. Nevertheless, the Tm(II) and Dy(II) compounds have proved to be useful reducing agents by Bochkarev and Evans and their collaborators, both in inorganic [34–38] and organic [32,39] systems.

A recent review by Bochkarev provides a useful survey of arene–Ln complexes [40].

2.2. The tris(cyclopentadienyl)lanthanides as substrates

2.2.1. The general strategy

A range of compounds $[\text{LnCp}_3^x]$ {Ln = La, Ce, Pr, Nd; Cp^x = $\eta^5\text{-C}_5\text{H}_3(\text{SiMe}_3)_{2-1,3}$ [Cpⁿ], $\eta^5\text{-C}_5\text{H}_3\text{Bu}_2\text{-1,3}$ [Cp^h], $\eta^5\text{-C}_5\text{H}_4(\text{SiMe}_2\text{Bu})$ [Cp^l]} [41a] was used in the studies to be reported; in some case the corresponding mono-chlorides $\{[\text{LnCp}_2^x(\mu\text{-Cl})]\}_2$ [41b] were also required.

The strategy adopted in an effort to gain access to novel Ln(II) compounds was to reduce various $[\text{LnCp}_3^x]$ complexes with potassium metal under a variety of conditions.

As a preliminary to chemical experiments, cyclic voltammetry of the compounds $[\text{LaCp}_3^x]$ and $[\text{LaCp}_3^y]$, in thf with 0.2 mol dm⁻³ $[\text{NBu}_4][\text{PF}_6]$ as supporting electrolyte at a vitreous carbon working electrode at variable scan rates, showed that although the $\text{Ln}^{3+} \rightarrow \text{Ln}^{2+}$ reduction was of high energy (Table 1), it was reversible [42]. It is noteworthy that the bis(silyl)-substituted substrate $[\text{LaCp}_3^x]$ was more readily reduced than the carbon analogue $[\text{LaCp}_3^y]$, consistent with the notion that the silyl substituents help to delocalise the negative charge in $[\text{LaCp}_3^x]^-$. It was later shown [43] that there was little difference in $E_{1/2}$ values as between $[\text{LaCp}_3^x]$ and its Ce or Pr analogues, Table 1.

2.2.2. Synthetic and structural studies on $[\text{LnCp}_3^x]$ -K-neutral donor systems

The first synthetic study concerned the reaction of $[\text{LnCp}_3^x]$ (Ln = Ce or Nd) or $[\text{CeCp}_3^y]$ with a potassium mirror in 1,2-dimethoxyethane (dme) at –33 to 20 °C, yielding the complexes **1** and **2**, Scheme 1 [44]. It was clear that under these mild conditions the C–O bond of dme had been cleaved, ethene being the coproduct. It was suggested that Ln(II) intermediates, $[\text{M}(\text{dme})_n][\text{LnCp}_3^x]$ (M = K or Li) and/or LnCp_2^x were implicated. The X-ray structures of $\{[\text{CeCp}_2^y(\mu\text{-OMe})]\}_2$ and $[\text{NdCp}_2^y(\mu\text{-OMe})_2\text{Li}(\text{dme})]$ were provided.

When the above reaction was repeated using the colourless, diamagnetic $[\text{LaCp}_3^y]$ as substrate, first at –40 °C than at 25 °C, an immediate deep blue colour was observed which persisted for many hours [42]. Examination of the EPR spectrum at 295 K, Fig. 1a,

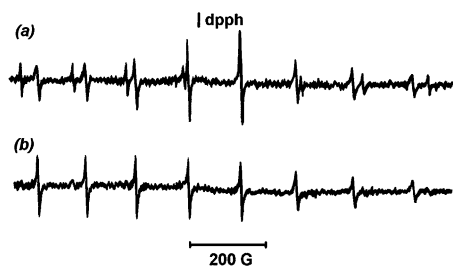

Fig. 1. EPR spectrum of the blue solution of Eq. (2) at: (a) 295; and (b) 275 K.

revealed that two different paramagnetic La(II) species **3** and **4** had formed, as evident from the presence in the spectrum of two sets of well resolved $S = 1/2$ metal-centred octuplets with **3**:**4** in ratio of ca. 1.5:1. Each of the **3** and **4** sets arose from the hyperfine coupling of the unpaired electron with the ^{139}La nucleus (99.91% natural abundance, $\mu_1 = +2.776$, $I = 7/2$), with $g_3 = 1.972(8)$, $a_3(^{139}\text{La}) = 134.0(5)$ G and $g_4 = 1.970(8)$, $a_4(^{139}\text{La}) = 145.0(5)$ G. Variable temperature EPR spectra showed that at 275 K signals of **4** had disappeared (Fig. 1b), while at 330 K **4** became the major species. These features were reversed upon cooling. Upon stronger heating the blue solution was decolourised and $[\{\text{LaCp}''_2(\mu\text{-OMe})\}_2]$ (**1c**) and X-ray characterised [45] $[\{\text{K}(\mu\text{-}\eta^5\text{-Cp}'')\}_\infty]$ were isolated. It was concluded that a plausible interpretation of these data was that shown in Eq. (2) [42].

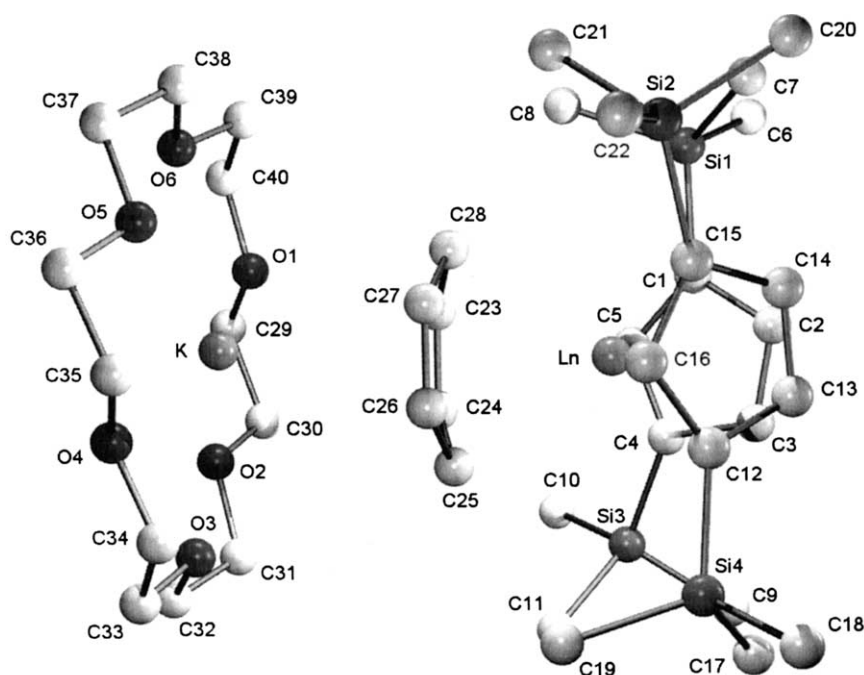
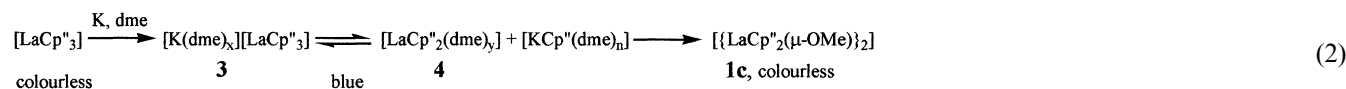
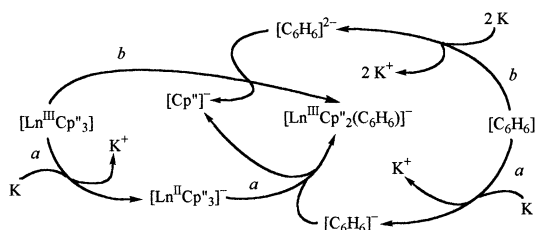

Fig. 2. The molecular structure of the isostructural compounds $[\text{K}(\text{[18]crown-6})][\text{LnCp}''_2(\eta^2\text{-C}_6\text{H}_6\text{-1,4})]$ **5a**, **5b** and **5d**.

Next the neutral donor was changed from dme to the crown ether ([18]crown-6). Treatment of the appropriate $[\text{LaCp}''_3]$ ($\text{Ln} = \text{La, Ce, Pr, Nd}$) with two equivalents each of potassium and the crown ether in benzene at ambient temperature afforded the lanthanate(III) complexes **5**, containing the 1,4-cyclohexa-2,5-dienyl ligand (the benzene-1,4-dianion), with $[\text{K}(\text{[18]crown-6})\text{Cp}'']$ (**6**) as coproduct, Eq. (3) [46,47]. Crystallographic data are available for **5a** [46], **5b** [47] and **5d** [47]. The evidence for the complexes **5** being Ln(III) species rests on: (i) the diamagnetism of **5a**; (ii) the hydrolysis of each of the complexes **5** yielding cyclohexa-1,4-diene as well as benzene; and (iii) the crystallographic data for **5a**, **5b** and **5d**, Fig. 2. As for (iii), the molecular structures of these isomorphous salts reveal that each comprises a tight ion pair, a C_6H_6 ligand bridging the K and Ln atoms; the potassium atom has close contacts to the six crown ether oxygen atoms and the centroids of the 2,3- and 5,6- carbon atoms of the C_6H_6 ligand. The latter is boat-shaped. The reaction of $[\text{LaCp}''_3]$ with K and ([18]crown-6) in benzene, monitored by EPR spectroscopy revealed the presence of at least four paramagnetic La(II) intermediates to the eventual complex **5a** [47]. Two alternative pathways (a and b in Scheme 2) from $[\text{LnCp}''_3]$ to the compounds **5** were proposed [47].

Treatment of $[\text{LnCp}''_3]$ with an excess of K (ca. 3 mol) and ([18]crown-6) in benzene at ambient temperature initially afforded a dark red, diamagnetic ($^1\text{H-NMR}$)



Scheme 2. Alternative pathways (a) and (b) to the anions of **5a–5d** from $[\text{LnCp}_3]$, K and [18]crown-6.

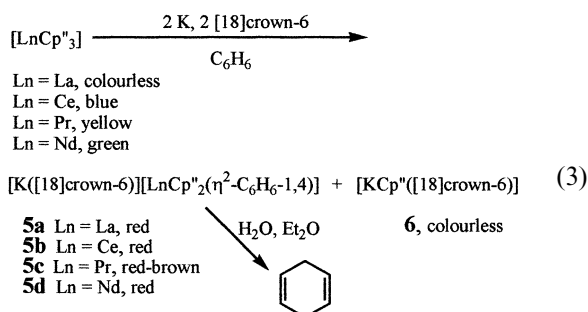

solution containing the La(III) complex **5a**, which during ca. 1 h yielded a paramagnetic green powder, believed to be **7a** [48]. At that time (1998) X-ray-quality crystals of **7a** were not obtained; hence, the same experiment was repeated but using $[\text{LaCp}_3]$ as precursor, which yielded a diamagnetic red intermediate, believed to be **5e** which reverted slowly to the green lanthanate(II) salt **7b**, [Eq. (4)], which was X-ray-characterised, Fig. 3. Complex **7a** was also accessible by heating **5a** in benzene. The molecular structure of **7b** shows the centrosymmetric anion to be binuclear with two LaCp^x_2 moieties bridged by a planar $\eta^6\text{-C}_6\text{H}_6$ ligand, which was regarded as a benzenide anion $[\text{C}_6\text{H}_6]^-$ [48] in contrast to the C_6H_6 ligand in **5a**, **5b** or **5d** which was considered to be a benzenide dianion $[\text{C}_6\text{H}_6]^{2-}$ [47]. These assignments are consistent with the selected geometric parameters shown in Fig. 4. Although **7b** was shown to be paramagnetic and EPR-active, detailed

magnetic, spectral and theoretical studies are still awaited. In the meantime, the anion of **7b** is assigned as comprising two La(II) centres bridged by $[\text{C}_6\text{H}_6]^-$; an alternative formulation, as derived from two La(III) centres bridged by an $[\eta^6\text{-C}_6\text{H}_6]^{3-}$ ligand is less plausible. Similar complexes **8a** and **8b** were prepared as summarised in Eq. (5) [49]. The X-ray structures of the isostructural compounds **8a** and **8b** were of poor quality because of the high disorder associated with the SiMe_3 and Me (of PhMe) groups, but were adequate to provide definitive evidence that their structures were as indicated in Eq. (5).

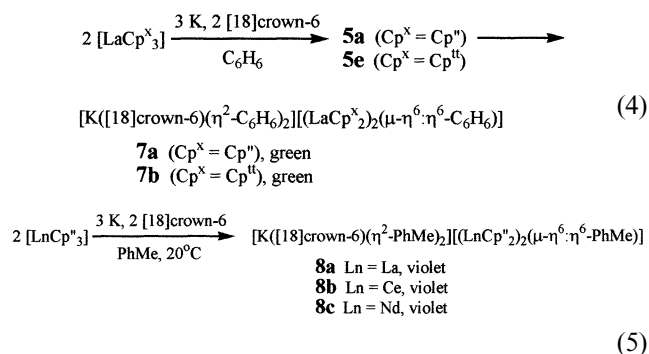

It was next demonstrated that the outcome of a reaction between $[\text{LnCp}_3]$, K and a neutral donor was dependent not only on the neutral donor, the choice of hydrocarbon solvent and stoichiometry, but also on the nature of Cp^x . Thus, using the reagents and conditions of Eq. (5) but changing the Cp^x ligand to $\text{C}_5\text{H}_4\text{SiMe}_2\text{Bu}^t$ ($\equiv \text{Cp}^t$), the products were the salts **9a** and **9b** (Fig. 5), Eq. (6) [49]. The differing pathways to the anions of the salts **8** and **9** were suggested to be those shown in Scheme 3. Thus, the first step was the reduction of $[\text{LnCp}_3]$ to the Ln(II) species **D** and **D'** [cf. **3** and **4**, in Eq. (2)], followed by, in the case of $\text{Cp}^x = \text{Cp}^t$, the abstraction of a hydrogen atom from toluene in the formation of **9** and bibenzyl. In the Cp^r system, on the other hand, this pathway was believed to

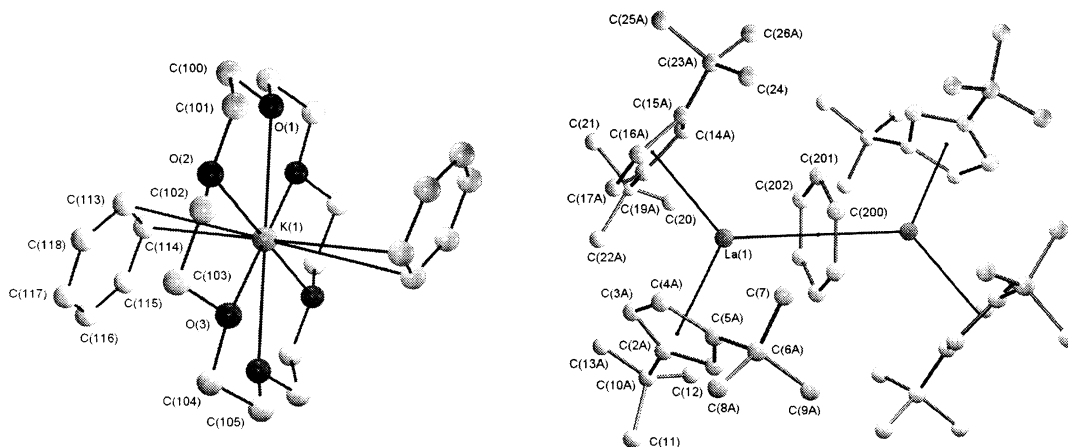

Fig. 3. The structure of $[\text{K}([18]\text{crown-6})(\eta^2\text{-C}_6\text{H}_6)_2][(\text{LaCp}^x_2)_2(\mu\text{-}\eta^6\text{-}\eta^6\text{-C}_6\text{H}_6)]$ (**7b**).

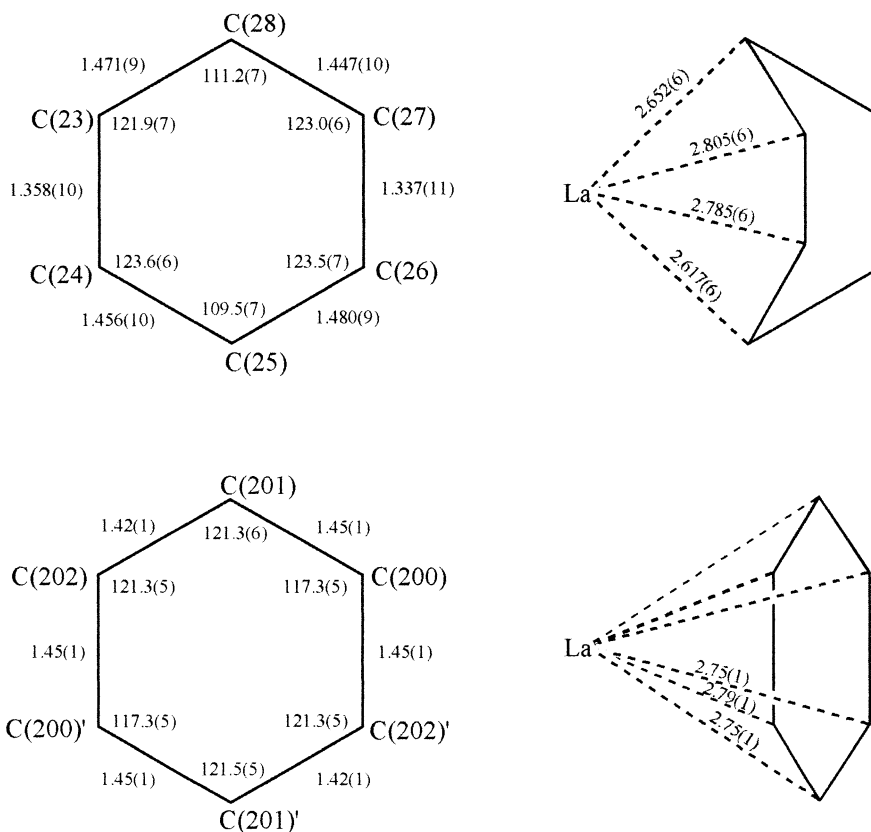
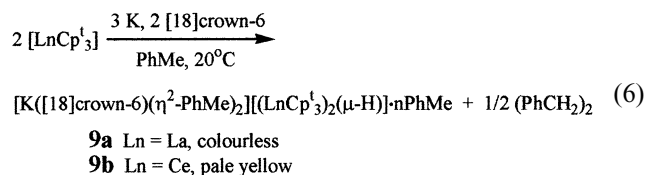

Fig. 4. Selected bond lengths and angles in the C_6H_6 ligand: (a) in **5a**; and (b) in **7b**.

be less favoured because of steric constraints and hence **D** preferentially eliminated $Cp^{* -}$ to yield **D'** which finally was transformed into **8**. Although the supposed bridging hydrido ligand in **9** was not located crystallographically, evidence for **9** rested on: (i) the diamagnetism of **9a** and the appropriate integration of the 1H -NMR spectral signals; (ii) the latter included a broad signal at δ 4.3, assigned to μ_2 -H which was absent in the deuterated analogue (prepared from toluene- d_8); (iii) the Ce...Ce separation of 4.513 Å in **9b**, which was comparable to the Lu...Lu separation of 4.18 Å in $[Na(thf)_6][LuCp_3)_2(\mu-H)]$ (prepared from $LuCp_3$ and NaH in thf; the bridging H was also not located) [50]; and (iv) the IR spectrum of **9a** and **9b** and their μ_2 -D analogues which indicated that the bridging $^1H^-$ was responsible for an absorption at 1285 cm^{-1} (918 cm^{-1} for the μ_2 - 2H).



Reactions of Ln(II) complexes of type **7** and **8** have not yet been extensively investigated, but two examples are illustrated in Scheme 4. Thus, heating **8c** in toluene

afforded the dibenzylneodyocenate(III) salt **10**, whereas water-splitting by **7c** gave the Nd(III)-containing salt **11**. Both **10** and **11** were isolated in X-ray-crystalline form and their molecular structures have been determined: **10** [51], **11** [52]. The reduction reactions could also be carried out using sodium, as illustrated in the formation of the X-ray-characterised Ln(II) compound **12** from $[LaCp^*_3]$, Eq. (7) [51].

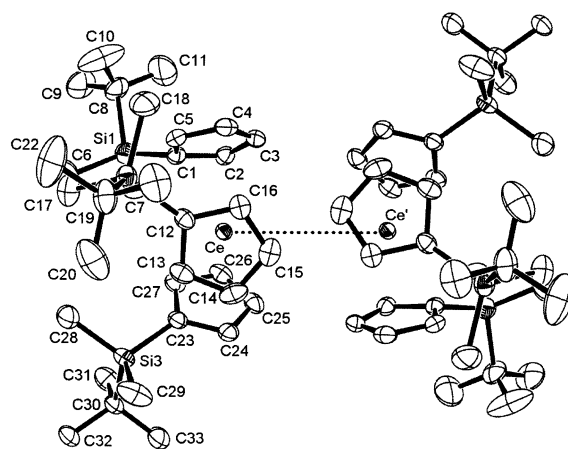
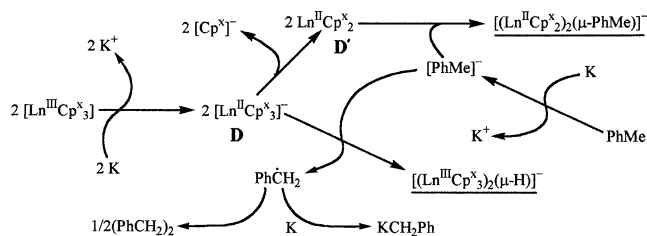
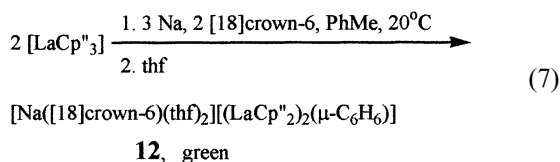

Fig. 5. The structure of the anion of $[K([18]\text{crown-6})(\eta^2\text{-PhMe})_2][(CeCp^*_3)_2(\mu\text{-H})]$ (**9b**) ($\mu\text{-H}$ not located).

Scheme 3. Pathways to the anions of **8** and **9**.

2.2.3. Experiments on arene–potassium systems

In the light of the experiments described in Section 2.2.2, it seemed desirable to examine reactions in mononuclear arene–alkali metal systems, possibly as a prelude to investigate the behaviour of the products towards $[\text{LnCp}^*_3]$.

As background, it had been established that two poly(trimethylsilyl)benzenes yielded X-ray-characterised crystalline products: $[\text{Li}(\text{thf})_2][\text{C}_6(\text{SiMe}_3)_6]$ (**E**) [53], $[\text{Li}(\text{dme})_2][\text{C}_6\text{H}_2(\text{SiMe}_3)_{4-1,2,4,5}]$ (**F**) [54] and $[\text{Na}(\text{dme})_3][\text{C}_6\text{H}_2(\text{SiMe}_3)_{4-1,2,4,5}]$ (**G**) [55], which may be regarded as substituent-stabilised derivatives of an $[\text{arene}]^{2-}$ (**E**, **F**) or $[\text{arene}]^-$ (**G**). The two lithium atoms in **E** are on the same side of the boat-shaped C_6 ring in

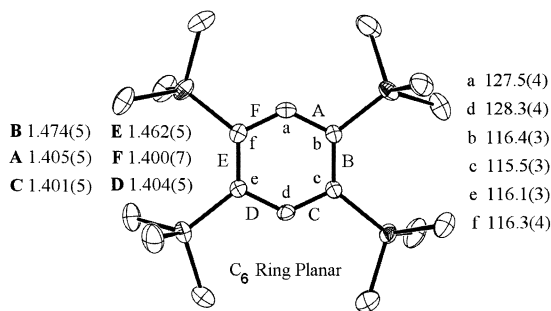
Fig. 6. The structure of the anion of $[\text{K}([18]\text{crown-6})(\text{thf})_2][\text{C}_6\text{H}_2(\text{SiMe}_3)_{4-1,2,4,5}]$ (**14**).

E [53], whereas in **F** the lithium atoms are on opposite sides of the centroid of the almost planar C_6 ring [54]. The salt **G** crystallises as a solvent-separated ion pair; the anion deviates from planarity by slight ring torsions, $|\omega_{\text{ring}}| \leq 8^\circ$ [55].

Treatment of $\text{C}_6\text{H}_2(\text{SiMe}_3)_{4-1,2,4,5}$ with an excess of potassium and two equivalents of $([18]\text{crown-6})$ in benzene at ambient temperature afforded the 2:1 adduct $[\text{K}([18]\text{crown-6})]_2[\text{ArH}]$ (**13**), as a microcrystalline product [45]. Crystallisation from $\text{thf-Et}_2\text{O}$ gave the 1:1 salt **14**. On the other hand, when using the arene $\text{C}_6\text{H}_4(\text{SiMe}_3)_{2-1,4}$, the product was the 1:1 adduct **15**. Attempts to derivatise **13**, by treating it with $[\{\text{LaCp}^*_2(\mu\text{-Cl})\}_2]$, furnished a mixture of solids, **5a**, **7a** and the X-ray-characterised compound **16**, Scheme 5. The $[\text{ArH}]^-$ anion of the solvent-separated ion pair **14** has a planar C_6 ring, the geometric parameters of which indicate a two-fold allylic delocalisation in the frag-

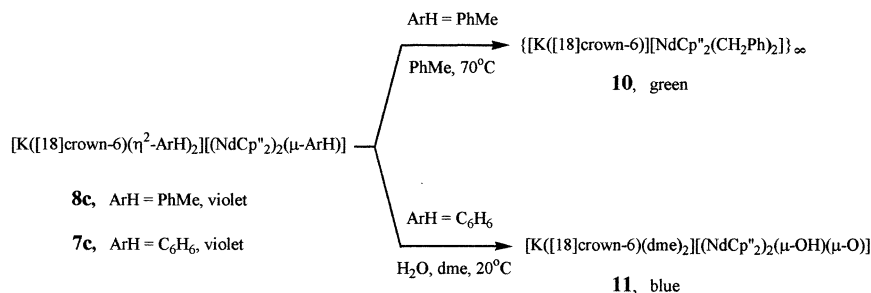

Scheme 4. Two hydrogen-atom abstraction reactions.

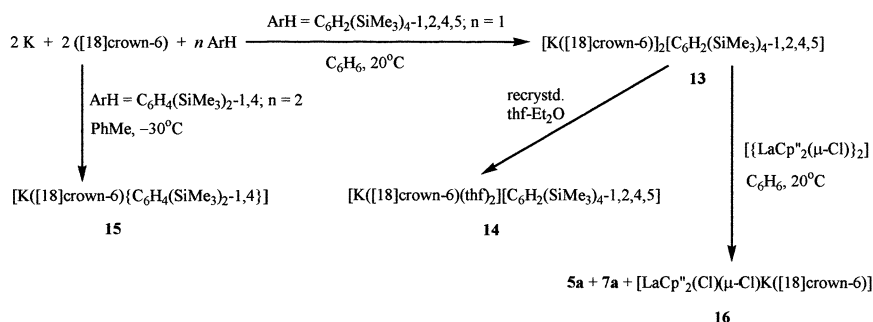
Scheme 5. Synthesis of the potassium salts containing the ligand $[\text{ArH}]^{2-}$ (**13**) or $[\text{ArH}]^-$ (**14**, **15**) and the conversion of **13** into **14**.

ments (1,2,3) and (4,5,6), Fig. 6. By contrast, **15** is a tight ion pair, in which the crown-encapsulated potassium ion is positioned orthogonal to the centroid of the C₆ ring, Fig. 7 [45].

Of more direct relevance to the results reported in Section 2.2.2 was a study of the system benzene- or toluene–potassium–([18]crown-6). The black, paramagnetic, crystalline (EPR: $g = 2.00296$) salt **17**, containing the toluene radical anion, was obtained [(i) in Scheme 6] in a slow, low temperature reaction between PhMe,

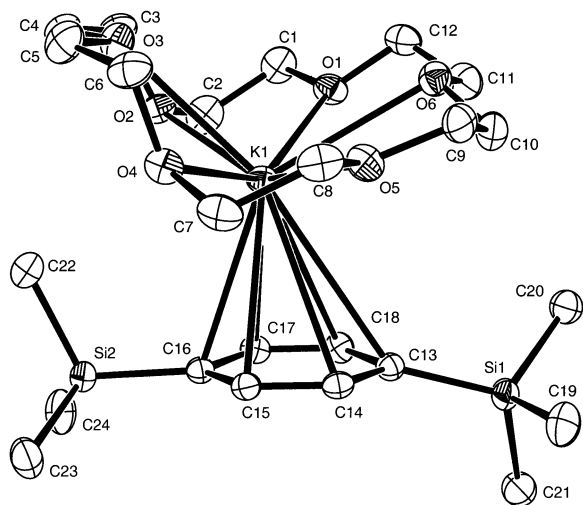
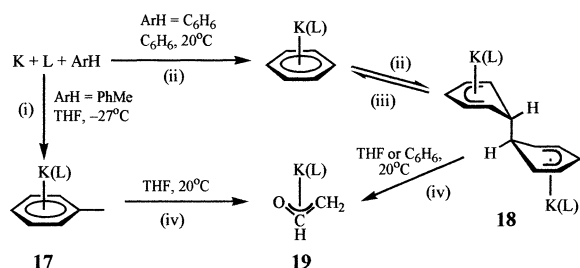

Fig. 7. The molecular structure of $[K([18]crown-6)\{C_6H_4(SiMe_3)_2-1,4\}]$ (**15**).



Scheme 6. Synthesis of the crystalline complexes **17**–**19** from K, ([18]crown-6) (= L) and PhMe or C₆H₆.

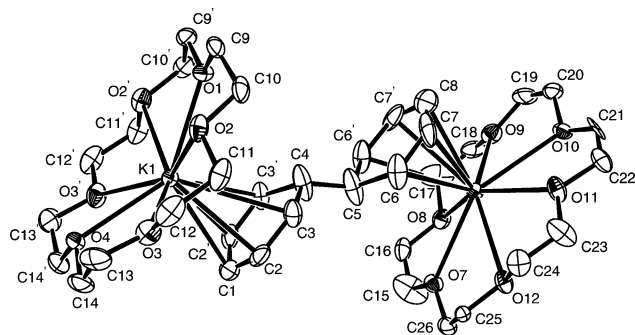

Fig. 8. The molecular structure of $\{K([18]crown-6)\}_2(\mu-\eta^5:\eta^5-C_6H_6-C_6H_6)$ (**18**).

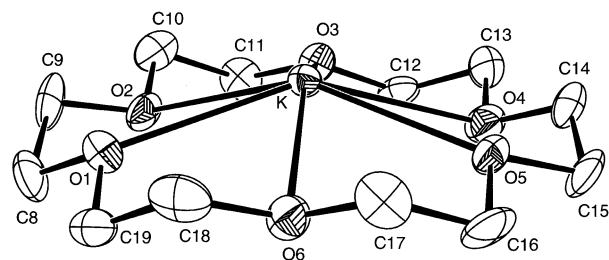
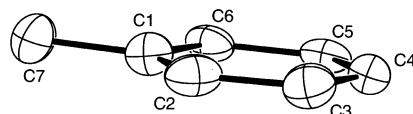

Fig. 9. The molecular structure of $[K([18]crown-6)(\eta^6-PhMe)]$ (**17**).

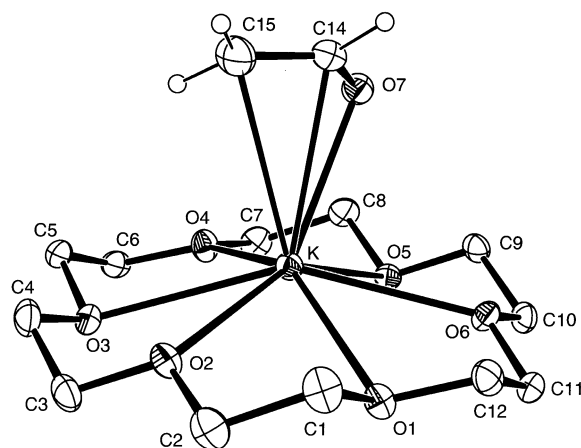

Fig. 10. The molecular structure of $[K([18]crown-6)(\eta^3-CH_2CHO)]$ (**17**).

K and ([18]crown-6) [56]. By contrast, from benzene in place of toluene, at ambient temperature, the final crystalline product was the red, diamagnetic salt **18** [(ii) in Scheme 6], containing the bis(benzene) dianion [56]. The structure of **18** is that of a tight ion-triple, in which the 3,3'-bis(cyclohexa-1,4-dienediyl) ligand is $\eta^5:\eta^5$ -bound in a transoid fashion to each of the two crown-encapsulated potassium cations, with the C_{sp³}–C_{sp³} bond length [C4–C5 in Fig. 8] of 1.461(11) Å. The only other X-ray-characterised examples of this ligand are found in $[\{Mn(CO)_3\}_2(\mu-\eta^5:\eta^5-C_6H_6-C_6H_6)]$ (**H**) [57] and $[(FeCp)_2(\mu-\eta^5:\eta^5-C_6H_6-C_6H_6)]$ (**I**) [58]. The fold angle in each C₆H₆ moiety of **18** is much smaller (15.7 and 12.5° about the C3...C3' and C6...C6' vectors, respectively) and the C4–C5 bond length much shorter than in **H** or **I**, attributed [56] to the different metal-to-ligand bonding modes: ionic (**18**) or covalent (**H**, **I**). Compound **18** was sparingly soluble in both benzene and thf, but dissociated therein to give a solution containing the benzene radical anion [(iii) in Scheme 6] [EPR: septet, $g = 2.0067$, $a(^1H) = 3.63$ G] and finally in

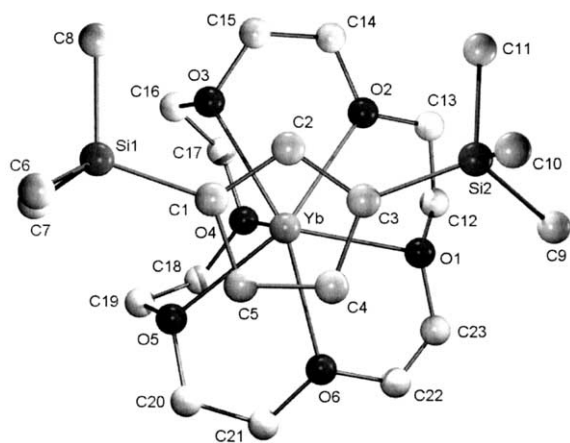

Fig. 11. The structure of the cation of $[\text{YbCp}''([\text{18}]\text{crown-6})][\text{Cp}''] \cdot 3\text{C}_6\text{H}_6$ (**21**).

low yield [(iv) in Scheme 6] yellow crystals of the potassium η^3 -enolate **19**. The structure of the crystalline salt **17**, Fig. 9, has the crown-encapsulated potassium bound in an approximate η^6 -fashion to the planar C_6H_5 ring [56]. The salt was sparingly soluble in toluene and in thf it gave a deep blue solution which readily decomposed at ambient temperature, the crystalline enolate salt, a tight ion pair (Fig. 10), **19** being a major product, (v) in Scheme 6.

3. Cationic mononuclear samarium(II) and ytterbium(II) organic complexes

Although cationic inorganic Ln(II) complexes (Ln = Sm, Eu, Yb) are known, such as $[\text{Yb}(\text{hmpa})_4(\text{thf})_2]\text{I}_2$

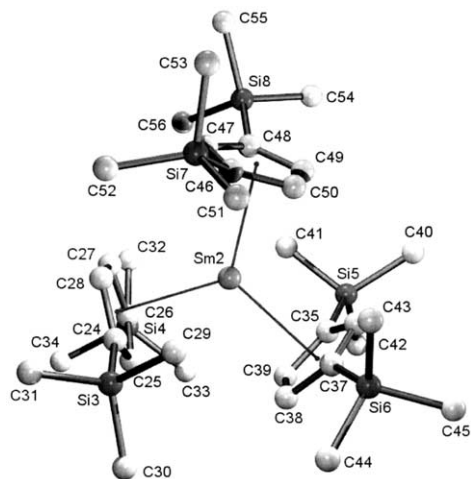
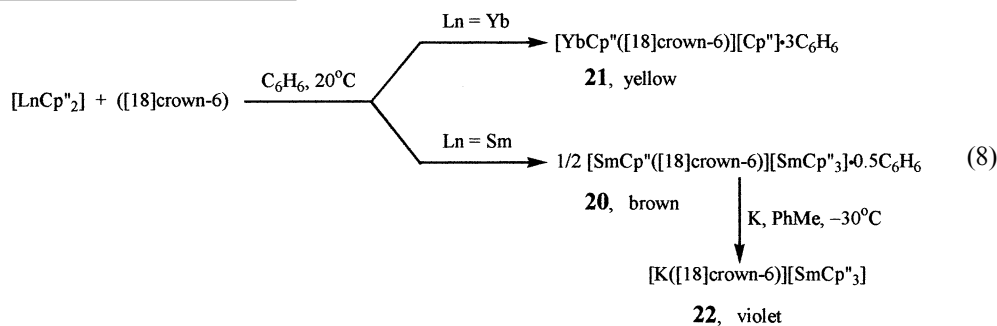

Fig. 12. The structure of the anion of $[\text{SmCp}''([\text{18}]\text{crown-6})][\text{SmCp}''_3] \cdot 0.5\text{C}_6\text{H}_6$ (**20**).

The initial strategy was to select a compound LnCp''_2 (Ln = Sm, Yb) as the substrate, and cause it to react with a strong neutral nucleophile N which would be capable of displacing a $[\text{Cp}'']^-$ ligand, a good leaving group by virtue of its aromaticity. As N, the choice fell on ([18]crown-6) [61]. The syntheses of the crystalline salts **20** (Ln = Sm) and **21** (Ln = Yb), both containing the $[\text{LnCp}''([\text{18}]\text{crown-6})]^+$ cation, are summarised in Eq. (8). The $[\text{SmCp}''_3]^-$ anion, as found in the salt **20**, was also accessible in the form of the X-ray-characterised [61] salt **22** from the reaction in equivalent proportions of SmCp''_2 , KCp'' and ([18]crown-6) in toluene at ambient temperature, or alternatively [Eq. (8)] from the salt **20** and potassium.



[59] or $[\text{Sm}(\text{thf})_7][\text{Zn}_4(\mu_2\text{-SePh})_6(\text{SePh})_4]$ [60], as are heterobimetallic complexes such as $[\text{Eu}(\text{thf})_4(\mu_3\text{-SePh})_3\text{Zn}(\text{SePh})]$ [60], cationic mononuclear organic Ln(II) complexes were unknown prior to our work in 1998 [61]. Our objective was to gain access to salts in which the cation contained a Ln–X moiety, X^- being a monoanionic organic ligand. Such a species would feature a highly electropositive Ln(II) centre and hence be susceptible to attack by a nucleophile such as an alkene, as a first step followed by an insertion of the latter into the Ln–X bond.

The crystalline salt **21** consists of well-separated ions. The centroid of the Cp'' ring and six oxygen atoms of the neutral ligand form a strongly distorted pentagonal bipyramid around the central Yb of the cation, Fig. 11. Crystalline **20**, likewise, has well-separated ions, the cation resembling that of **21**, the anion being illustrated in Fig. 12. The difference in the outcome of the reactions of Eq. (8) leading to the samarium (**20**) and ytterbium (**21**) salts was attributed to steric effects, the bigger Sm^{2+} being able in the form of SmCp''_2 to trap the $[\text{Cp}'']^-$ ion

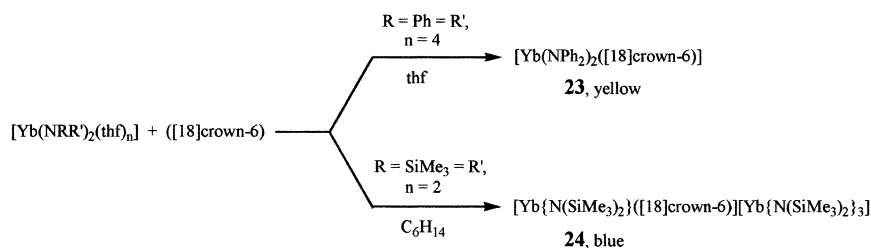

Scheme 7. Reactions of Yb(II) amides with ([18]crown-6).

which may well have been the initial product also in the Sm system. In support of this postulate, it was observed that whereas the crystalline salt **20** was unchanged when dissolved in toluene-*d*₈, the ytterbium salt **21** in the same solvent was shown to be an equilibrium mixture of two components, one structurally similar to the crystal and the other probably [YbCp₂'([18]crown-6)] [61].

The experiments described above, as far as derivative chemistry is concerned, was in one sense a feasibility study, in that cations of the form [LnX([18]crown-6)]⁺ were unlikely candidates for insertion reactions into the Ln–X bond for X = Cp'. Hence, attention turned to changing the X[−] ligand. In the first instance the choice fell on amido [NRR'][−] ligands, partly because Ln–(NRR')₂ precursors were, in principle, readily accessible for Ln = Sm or Yb. In Scheme 7 are summarised experiments with two Yb(II) amides. Treatment with ([18]crown-6) gave the neutral, monomeric Yb(NPh₂)₂-crown ether 1:1-adduct **23**, while with the more sterically encumbered ytterbium(II) bis(trimethylsilyl)amide the product was the crystalline salt **24** containing the targeted [Yb{N(SiMe₃)₂}([18]crown-6)]⁺ cation [62]. The structure of **23** is unusual in that the amido groups are on opposite sides of the ([18]crown-6)-encapsulated ytterbium ion, with the angle N–Yb–N' = 176.6°, Fig. 13. Interestingly its crystalline ligand precursor [K(NPh₂)₂([18]crown-6)] (**25**) showed the potassium ion to be η⁶-coordinated to one of the Ph-rings rather than the amido nitrogen atom, Fig. 14. The crystalline complex **24** was extremely air-, light- and heat-sensitive. An X-ray diffraction study showed the presence of [Yb{N(SiMe₃)₂}₃][−] and a highly disordered cation, which was qualitatively adequate to confirm the nature of the amidoytterbium(II) cation. This salt structure of **24** was confirmed by multinuclear (¹H, ¹³C, ²⁹Si, ¹⁷¹Yb)-NMR spectroscopy, e.g. δ[¹⁷¹Yb{¹H}] = 252 (cation), 851 (anion) at 298 K in ^tBuOMe–C₆D₆.

4. Low valent samarium and ytterbium β-diketiminates

The β-diketiminato ligands are of structure **J**. Those relevant to the present study have the substituents R¹ = SiMe₃ = R⁵ (i.e. R) and R³ = H. They are readily

synthesised as lithium derivatives; for example for R² = Ph = R⁴ (**J'**), from LiCHR₂ + 2PhCN [63]. An alternative precursor is the potassium β-diketiminato available from the lithium salt Li(**J**) and KO^tBu [64]. Two unusual heterobimetallic, paramagnetic, crystalline compounds **26** and **27** were obtained in modest yield from the reagents shown in Eqs. (9) and (10), respectively [65]. The former was obtained from a green Et₂O and the latter from a violet benzene solution. The crystalline complex **26** is a centrosymmetric dimer. One

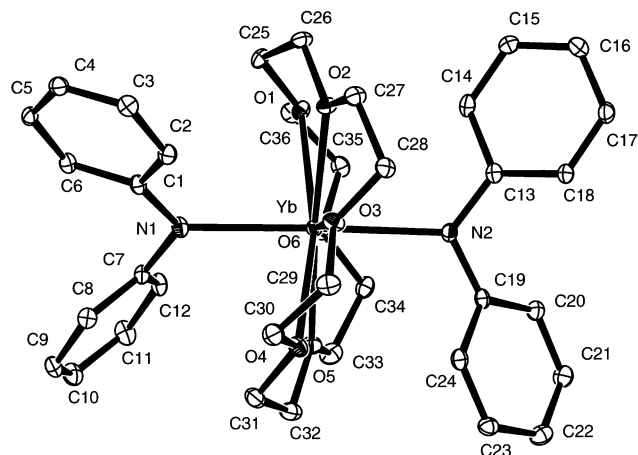
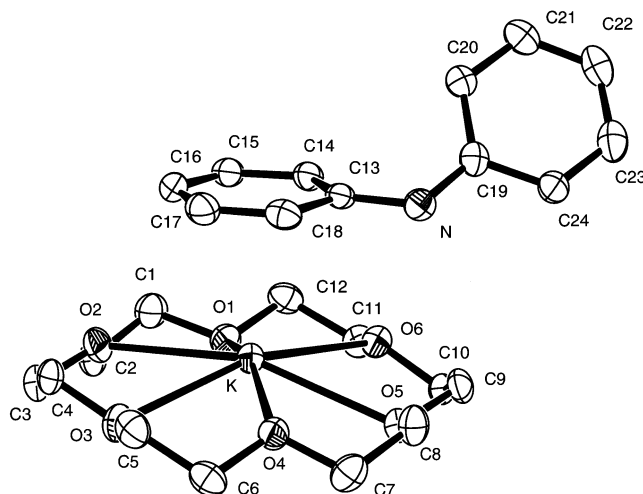
Fig. 13. The molecular structure of [Yb(NPh₂)₂([18]crown-6)] (**23**).Fig. 14. The molecular structure of [K(NPh₂)₂([18]crown-6)] (**25**).

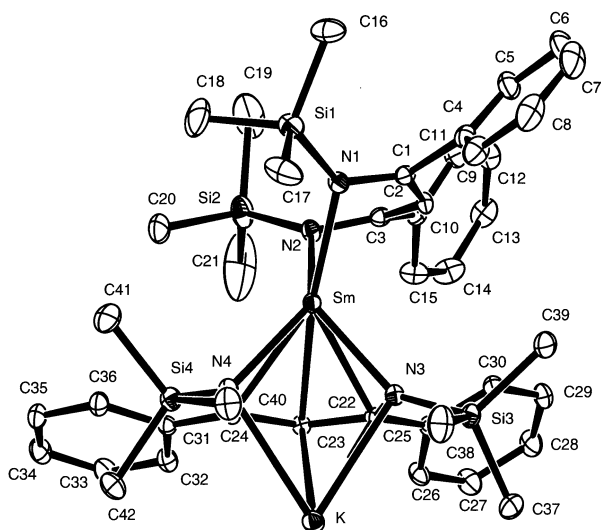

Fig. 15. The molecular structure of $[\{K(\mu\text{-J})\text{SmJ}\}_2]$ (**26**), showing a single unit of the dimer.

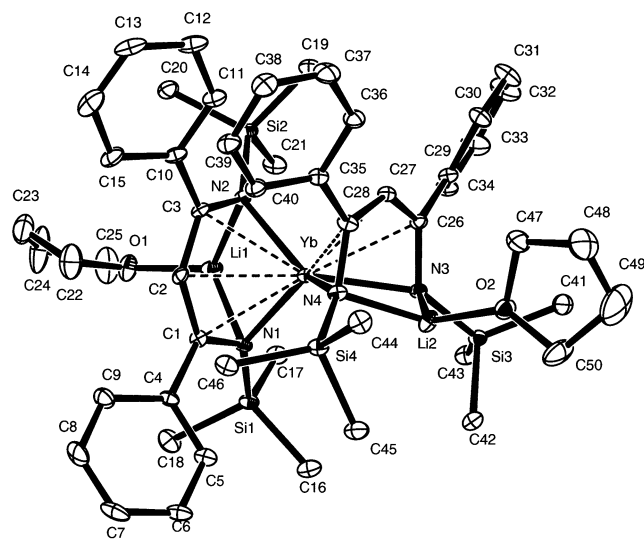
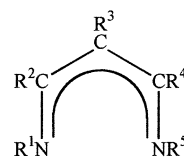

Fig. 16. The molecular structure of $[\{\text{Li}(\text{thf})_2\text{Yb}(\text{J})_2\}]$ (**27**).

of the **J** ligands of the monomeric moiety (Fig. 15) not only bridges the Sm and K ions by *N,N'*-contacts but also acts as bridge to the **K'** ion of an adjacent second monomeric moiety. The second **J** ligand of each monomeric unit is bound in an *N,N'*-chelating fashion as a terminal ligand to the Sm ion. The structure of the crystalline complex **27** (Fig. 16) has a central $\text{Yb}(\text{J})_2$ core, having the four-coordinate Yb atom as the spiro centre. Each **J** ligand also functions as an *N,N'*-bridge to a thf-coordinated lithium ion.

A major question, to which a definitive answer is not yet available, must await detailed spectroscopic, magnetic and computational input; it relates to the oxidation state of the Ln ion in **26** and **27**. A simplistic interpretation would assign the former as a Sm(I) and the latter as an Yb(0) complex, by assuming that the **J**

ligand is uninegative. An equally simple interpretation would be to regard each as an Ln(II) complex by attributing a formal -2 charge to each of the bridging bound **J'** ligands.



J

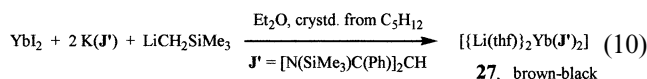
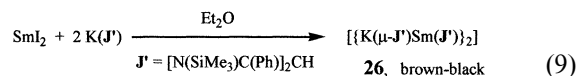
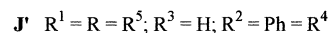

5. Mononuclear cerium(IV) amides and a mixed valence trinuclear Ce(IV)/Ce(III) cluster

Although the inorganic Ce(IV) salt $[\text{NH}_4]_2[\text{Ce}(\text{NO}_3)_6]$ is widely used as a reagent in organic synthesis (under the acronym CAN, cf. Ref. [66]), well authenticated organic Ce(IV) compounds, excluding *O*-donor complexes, such as the X-ray-characterised $[\text{Ce}(\text{O}^t\text{Bu})_2(\text{NO}_3)_2(\text{HO}^t\text{Bu})_2]$ [67], $[\text{Ce}(\text{O}^t\text{Bu})_2(\mu\text{-O}^t\text{Bu})_2(\mu_3\text{-O}^t\text{Bu})_2\{\text{Na}(\text{dme})\}_2]$ [67], $[\{\text{Ce}(\text{OC}^t\text{Bu}_3)_2\}_3(\mu\text{-OC}_6\text{H}_4\text{O}-1,4)]$ [68], $[\text{Ce}\{\text{C}_6\text{H}_{11}\text{-}c\}_8\text{Si}_8\text{O}_{13}\}_3(\text{py})_3]$ [69] and $[\text{CeCp}_3(\text{OR}')]$ ($\text{R}' = ^t\text{Bu}$ [70], ^iPr [71]), are rare. A major breakthrough was the report that the tetrapodal tris(amido)aminocerium(III) complex $[\text{Ce}(\text{NN}'_3)]$ was oxidised by I_2 to give the crystalline Ce(IV) product $[\text{Ce}(\text{NN}'_3)\text{I}][\text{NN}'_3 = \text{N}(\text{CH}_2\text{CH}_2\text{NSiMe}_2^t\text{Bu})_3]$, whereas Br_2 or Cl_2 gave the mixed valence compounds $[\{\text{Ce}(\text{NN}'_3)_2(\mu\text{-Hal})\}]$ (**K**) [72]. $[\text{Ce}\{\text{N}(\text{SiMe}_3)_2\}_3]$ was not oxidised by Cl_2 [73].

We have found that it is possible to oxidise $[\text{Ce}\{\text{N}(\text{SiMe}_3)_2\}_3]$ to form the crystalline, diamagnetic tris(amido)cerium(IV) halides **28** and **29**, Eq. (11), albeit by using the rather unusual oxidants TeCl_4 for **28** [74] and PBr_2Ph_3 for **29** [73]. It may be significant that both these halide reagents dissociate in solution to form halogenonium ions $[\text{TeCl}_3]^+$ and $[\text{PBrPh}_3]^+$ and hence display enhanced electrophilicity in donor solvents which may lower the barrier to electron transfer. Complexes **28** [74] and **29** [73] are isostructural, Fig. 17, being C_3 symmetric about Ce–Hal axis. The Ce–N and Ce–Hal bonds are relatively short, but there is a notable elongation in the N–Si bond lengths of ca. 0.05 Å compared with the value in $[\text{Ce}\{\text{N}(\text{SiMe}_3)_2\}_3]$ [75]; the N–C–N' angle of $117.3(4)^\circ$ in both **28** [74] and **29** [73] is

close to an sp^2 value. The geometric data for **28** were in reasonable agreement with those computed for the model compound $[\text{CeCl}\{\text{N}(\text{SiH}_3)_2\}_3]$ [74]. Both **28** and **29** were unstable in solution [73,74].

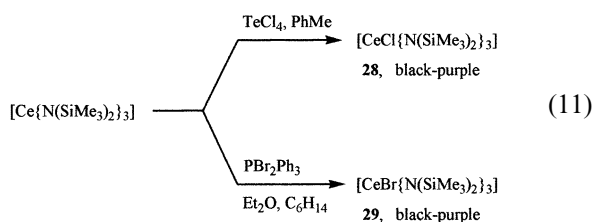

The reaction between a Ce(IV) *tert*-butoxide or nitrate and SnCp^*Me_3 was originally undertaken with the aim of displacing $[\text{O}^t\text{Bu}]^-$ and/or $[\text{NO}_3]^-$ ligands by $[\text{Cp}^*]^-$. In the event, the tin compound appeared to behave as a reducing agent, yielding the crystalline mixed valence trinuclear cluster compound **30**, Eq. (12) [76]. Its structure, illustrated in Fig. 18, consists of a central core of three cerium atoms arranged in an equilateral triangle, which are joined to one another by three doubly and two triply bridging $[\text{O}^t\text{Bu}]^-$ ligands. The cerium atom Ce1 has a single while each of Ce2 and Ce3 has two terminal $[\text{O}^t\text{Bu}]^-$ ligands. The coordination environment about Ce1 is completed by an *O,O'*-chelating $[\text{NO}_3]^-$ ligand. Analysis of the $^1\text{H-NMR}$ solution spectra and the geometric parameters of the crystalline complex **30** indicates that Ce1 is in the oxidation state +3, whereas Ce2 and Ce3 are of +4 type. Complex **30** appears to be the first mixed valence organic trinuclear cerium cluster; other mixed valence compounds include **K** [72] and $[\text{Ce}_4(\mu_4\text{-O})(\mu_3\text{-O}^i\text{Pr})_2(\mu_2\text{-O}^i\text{Pr})_4(\text{O}^i\text{Pr})_7(\text{HO}^i\text{Pr})]$ [77]. Density functional calculations were made on the triangular cluster compound **30**, which showed good agreement with the experimental geometrical parameters, and indicated that the *f*-electron behaves as a spectator, barely affecting the core geometry and only influencing the ligands indirectly via ionic bonding [76]. Localisation of this electron on Ce1

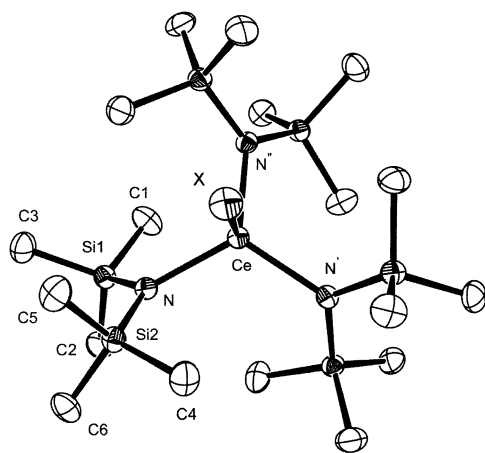

Fig. 17. The molecular structure of $[\text{Ce}\{\text{N}(\text{SiMe}_3)_2\}_3\text{X}]$ ($\text{X} = \text{Cl}$, **28**; Br , **29**).

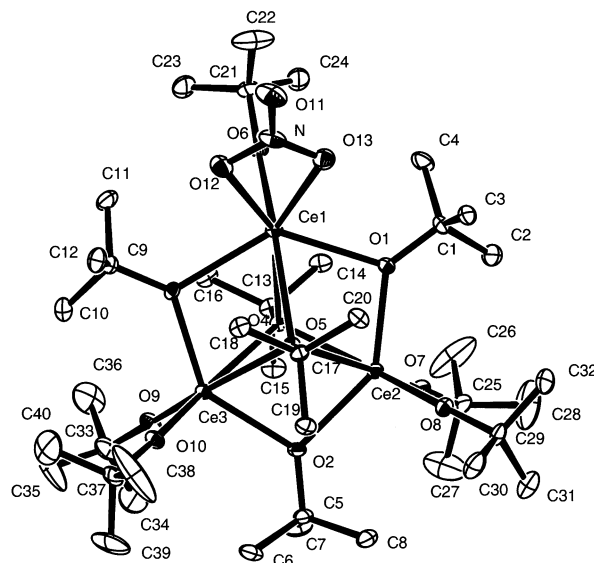
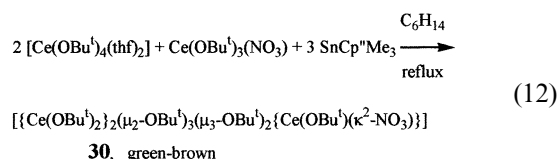

Fig. 18. The molecular structure of $[\{\text{Ce}(\text{O}^t\text{Bu})_2\}_2(\mu_2\text{-O}^t\text{Bu})_3(\mu_3\text{-O}^t\text{Bu})_2\{\text{Ce}(\text{O}^t\text{Bu})(\text{NO}_3)\}]$ (**30**).

is favoured, giving the $^2A'$ ground state. However, the *f*-electron may localise on Ce2/Ce3 with only a slight energetic penalty (ca. 18 kJ mol^{-1} for $^2A''$) and with little effect on the rest of the cluster. This suggests that **30** may be a useful component in molecular-scale electronic switching.



Acknowledgements

We are grateful for valuable contributions made by Professors F. Laschi (EPR; Refs. [42,46]) and H. Nöth (X-ray; Ref. [51]), Drs D.J. Duncalf (X-ray; Ref. [47]), C.J. Pickett and S.K. Ibrahim (cyclic voltammetry), Professors O. Eisenstein and L. Maron (DFT, Ref. [74]), Dr. S.D. Elliott (DFT, Ref. [76]) and A.G. Avent (NMR). We also acknowledge with thanks the support received from EPSRC and The Royal Society.

References

- [1] M.F. Lappert, R. Pearce, J. Chem. Soc. Chem. Commun. (1973) 24.
- [2] P.B. Hitchcock, M.F. Lappert, R.G. Smith, R.A. Bartlett, P.P. Power, J. Chem. Soc. Chem. Commun. (1988) 1007.
- [3] J.L. Atwood, W.E. Hunter, R.D. Rogers, J. Holton, J. McMeeking, R. Pearce, M.F. Lappert, J. Chem. Soc. Chem. Commun. (1978) 140.

- [4] (a) J.L. Atwood, M.F. Lappert, R.G. Smith, H. Zhang, *J. Chem. Soc. Chem. Commun.* (1988) 1308;
(b) P.B. Hitchcock, M.F. Lappert, R.G. Smith, *J. Chem. Soc. Chem. Commun.* (1989) 369.
- [5] (a) J. Holton, M.F. Lappert, G.R. Scollary, D.G.H. Ballard, R. Pearce, J.L. Atwood, W.E. Hunter, *J. Chem. Soc. Chem. Commun.* (1976) 425;
(b) J. Holton, M.F. Lappert, D.G.H. Ballard, R. Pearce, J.L. Atwood, W.E. Hunter, *J. Chem. Soc. Chem. Commun.* (1976) 480;
(c) J. Holton, M.F. Lappert, D.G.H. Ballard, R. Pearce, J.L. Atwood, W.E. Hunter, *J. Chem. Soc. Dalton Trans.* 45 (1979) 54.
- [6] (a) P.B. Hitchcock, S.A. Holmes, M.F. Lappert, S. Tian, *J. Chem. Soc. Chem. Commun.* (1994) 2691;
(b) J.R. van den Hende, P.B. Hitchcock, S.A. Holmes, M.F. Lappert, S. Tian, *J. Chem. Soc. Dalton Trans.* (1995) 3933.
- [7] C. Eaborn, P.B. Hitchcock, K. Izod, J.D. Smith, *J. Am. Chem. Soc.* 116 (1994) 12071.
- [8] M.F. Lappert, P.I.W. Yarrow, J.L. Atwood, R. Shakir, J. Holton, *J. Chem. Soc. Chem. Commun.* (1980) 987.
- [9] (a) P.L. Watson, *J. Chem. Soc. Chem. Commun.* (1980) 652;
(b) H.A. Zinnen, J.J. Pluth, W.J. Evans, *J. Chem. Soc. Chem. Commun.* (1980) 810.
- [10] M.F. Lappert, A. Singh, J.L. Atwood, W.E. Hunter, *J. Chem. Soc. Chem. Commun.* (1981) 1190.
- [11] M.F. Lappert, A. Singh, J.L. Atwood, W.E. Hunter, *J. Chem. Soc. Chem. Commun.* (1981) 1191.
- [12] M.F. Lappert, A. Singh, J.L. Atwood, W.E. Hunter, H.-M. Zhang, *J. Chem. Soc. Chem. Commun.* (1983) 69.
- [13] (a) P.B. Hitchcock, M.F. Lappert, A. Singh, *J. Chem. Soc. Chem. Commun.* (1983) 1499;
(b) P.B. Hitchcock, M.F. Lappert, R.G. Smith, *Inorg. Chim. Acta* 139 (1987) 183.
- [14] B. Çetinkaya, P.B. Hitchcock, M.F. Lappert, R.G. Smith, *J. Chem. Soc. Chem. Commun.* (1992) 932.
- [15] J.R. van den Hende, P.B. Hitchcock, M.F. Lappert, *J. Chem. Soc. Dalton Trans.* (1995) 2251.
- [16] (a) G.B. Deacon, P.B. Hitchcock, S.A. Holmes, M.F. Lappert, P. MacKinnon, R.H. Newnham, *J. Chem. Soc. Chem. Commun.* (1989) 935;
(b) J.R. van den Hende, P.B. Hitchcock, S.A. Holmes, M.F. Lappert, W.-P. Leung, T.C.W. Mak, S. Prashar, *J. Chem. Soc. Dalton Trans.* (1995) 1427.
- [17] P.B. Hitchcock, J.A.K. Howard, M.F. Lappert, S. Prashar, *J. Organomet. Chem.* 437 (1992) 177.
- [18] P.B. Hitchcock, M.F. Lappert, S. Tian, *J. Chem. Soc. Dalton Trans.* (1997) 1945.
- [19] (a) D. Drees, J. Magull, *Z. Anorg. Allg. Chem.* 620 (1994) 814;
(b) D. Drees, J. Magull, *Z. Anorg. Allg. Chem.* 621 (1995) 948.
- [20] P.B. Hitchcock, M.F. Lappert, S. Tian, *J. Organomet. Chem.* 549 (1997) 1.
- [21] A.G. Avent, M.A. Edelman, M.F. Lappert, G.A. Lawless, *J. Am. Chem. Soc.* 111 (1989) 3423.
- [22] X. Cai, B. Gehrhuis, P.B. Hitchcock, M.F. Lappert, *Can. J. Chem.* 78 (2000) 1484.
- [23] F.G.N. Cloke, 1995. In: E.W. Abel, F.G.A. Stone, G. Wilkinson (Eds.), *Comprehensive Organometallic Chemistry II*. Pergamon, Oxford, vol. 4, M.F. Lappert (Ed.) (Chapter 1).
- [24] F.G.N. Cloke, K. Khan, R.N. Perutz, *J. Chem. Soc. Chem. Commun.* (1991) 1372.
- [25] P.L. Arnold, F.G.N. Cloke, P.B. Hitchcock, *Chem. Commun.* (1997) 481.
- [26] P.L. Arnold, F.G.N. Cloke, P.B. Hitchcock, J.F. Nixon, *J. Am. Chem. Soc.* 118 (1996) 7630.
- [27] P.L. Arnold, F.G.N. Cloke, J.F. Nixon, *Chem. Commun.* (1998) 797.
- [28] A. Greco, S. Cesca, G. Bertolini, *J. Organomet. Chem.* 113 (1976) 321.
- [29] M. Wedler, A. Recknagel, F.T. Edelmann, *J. Organomet. Chem.* 395 (1990) C26.
- [30] M.N. Bochkarev, I.L. Fedushkin, A.A. Fagin, T.V. Petrovskaya, J.W. Ziller, R.N.R. Broomhall-Dillard, W.J. Evans, *Angew. Chem. Int. Ed. Engl.* 36 (1997) 133.
- [31] M.N. Bochkarev, A.A. Fagin, *Chem. Eur. J.* 5 (1999) 2990.
- [32] W.J. Evans, N.T. Allen, J.W. Ziller, *J. Am. Chem. Soc.* 122 (2000) 11749.
- [33] M.N. Bochkarev, I.L. Fedushkin, S. Dechert, A.A. Fagin, H. Schumann, *Angew. Chem. Int. Ed. Engl.* 40 (2001) 3176.
- [34] I.L. Fedushkin, F. Girgsdies, H. Schumann, M.N. Bochkarev, *Eur. J. Chem.* (2001) 2405 (and references therein).
- [35] M.N. Bochkarev, I.L. Fedushkin, A.A. Fagin, H. Schumann, J. Demtschuk, *Chem. Commun.* (1997) 1783.
- [36] I.L. Fedushkin, M. Weydert, A.A. Fagin, S.E. Nefedov, I.L. Eremenko, M.N. Bochkarev, H. Schumann, *Z. Naturforsch. B* 54 (1999) 466.
- [37] M.N. Bochkarev, A.A. Fagin, I.L. Fedushkin, T.V. Petrovskaya, W.J. Evans, M.A. Greci, J.W. Ziller, *Russ. Chem. Bull.* 48 (1999) 1782.
- [38] W.J. Evans, N.T. Allen, J.W. Ziller, *J. Am. Chem. Soc.* 123 (2001) 7927.
- [39] W.J. Evans, N.T. Allen, *J. Am. Chem. Soc.* 122 (2000) 2118.
- [40] M.N. Bochkarev, *Russ. Chem. Rev.* 69 (2000) 783.
- [41] (a) S. Al-Juaid, Yu.K. Gun'ko, P.B. Hitchcock, M.F. Lappert, S. Tian, *J. Organomet. Chem.* 582 (1999) 143;
(b) P.B. Hitchcock, M.F. Lappert, S. Tian, *Organometallics* 19 (2000) 3420.
- [42] M.C. Cassani, M.F. Lappert, F. Laschi, *Chem. Commun.* (1997) 1563.
- [43] Yu.K. Gun'ko, S.K. Ibrahim, M.F. Lappert, C.K. Pickett, unpublished work.
- [44] Yu.K. Gun'ko, P.B. Hitchcock, M.F. Lappert, *J. Organomet. Chem.* 499 (1995) 213.
- [45] P.B. Hitchcock, M.F. Lappert, A.V. Protchenko, unpublished work.
- [46] M.C. Cassani, Yu.K. Gun'ko, P.B. Hitchcock, M.F. Lappert, *Chem. Commun.* (1996) 1987.
- [47] M.C. Cassani, Yu.K. Gun'ko, P.B. Hitchcock, M.F. Lappert, F. Laschi, *Organometallics* 18 (1999) 5539.
- [48] M.C. Cassani, D.J. Duncalf, M.F. Lappert, *J. Am. Chem. Soc.* 120 (1998) 12958.
- [49] Yu.K. Gun'ko, P.B. Hitchcock, M.F. Lappert, *Organometallics* 19 (2000) 2832.
- [50] H. Schumann, W. Genthe, E. Hahn, M.B. Hossain, D. van der Helm, *J. Organomet. Chem.* 299 (1986) 67.
- [51] Yu.K. Gun'ko, P.B. Hitchcock, M.F. Lappert, unpublished work.
- [52] Yu.K. Gun'ko, M.F. Lappert, H. Nöth, unpublished work.
- [53] A. Sekiguchi, K. Ebata, C. Kabuto, H. Sakurai, *J. Am. Chem. Soc.* 113 (1991) 1464.
- [54] A. Sekiguchi, K. Ebata, C. Kabuto, H. Sakurai, *J. Am. Chem. Soc.* 113 (1991) 7081.
- [55] H. Bock, M. Ansari, N. Nagel, Z. Havlas, *J. Organomet. Chem.* 499 (1995) 63.
- [56] P.B. Hitchcock, M.F. Lappert, A.V. Protchenko, *J. Am. Chem. Soc.* 123 (2001) 189.
- [57] S. Lee, S.R. Lovelace, D.J. Arford, S.J. Geib, S.G. Weber, N.J. Cooper, *J. Am. Chem. Soc.* 118 (1996) 4190.
- [58] V.G. Andrianov, Yu.T. Struchkov, V.A. Petrakova, N.A. Vol'kenau, *Koord. Khim.* 12 (1986) 978.
- [59] M. Berardini, T.J. Emge, J.G. Brennan, *Inorg. Chem.* 34 (1995) 5327.
- [60] Z. Hou, Y. Zhang, Y. Wakatsuki, *Bull. Chem. Soc. Jpn.* 70 (1997) 149.

- [61] Yu.K. Gun'ko, P.B. Hitchcock, M.F. Lappert, *Chem. Commun.* (1998) 1843.
- [62] P.B. Hitchcock, A.V. Khvostov, M.F. Lappert, A.V. Protchenko, *J. Organomet. Chem.* 647 (2002) 198.
- [63] P.B. Hitchcock, M.F. Lappert, M. Layh, D.-S. Liu, R. Sablong, T. Shun, *J. Chem. Soc. Dalton Trans.* (2000) 2301.
- [64] M.F. Lappert, D.-S. Liu, *J. Organomet. Chem.* 500 (1995) 203.
- [65] P.B. Hitchcock, A.V. Khvostov, M.F. Lappert, unpublished work.
- [66] V. Nair, J. Mathew, J. Prabhakaran, *Chem. Soc. Rev* 26 (1997) 127.
- [67] W.J. Evans, T.J. Deming, J.M. Olofson, J.W. Ziller, *Inorg. Chem.* 28 (1989) 4027.
- [68] A. Sen, H.A. Stecher, A.L. Rheingold, *Inorg. Chem.* 31 (1992) 473.
- [69] Yu.K. Gun'ko, R. Reilly, F.T. Edelman, H.-G. Schmidt, *Angew. Chem. Int. Ed. Engl.* 40 (2001) 1279.
- [70] W.J. Evans, T.J. Deming, J.W. Ziller, *Organometallics* 8 (1989) 1581.
- [71] A. Gulino, M. Cassarin, V.P. Conticello, J.G. Gaudiello, H. Mauermann, I. Fragalá, T.J. Marks, *Organometallics* 7 (1988) 2360.
- [72] C. Morton, N.W. Alcock, M.R. Lees, I.J. Munslow, C.J. Sanders, P. Scott, *J. Am. Chem. Soc.* 121 (1999) 11255.
- [73] P.B. Hitchcock, A.G. Hulkes, M.F. Lappert, unpublished work.
- [74] O. Eisenstein, P.B. Hitchcock, A.G. Hulkes, M.F. Lappert, L. Maron, *Chem. Commun.* (2001) 1560.
- [75] W.S. Rees, O. Just, D.S. Van Derveer, *J. Mater. Chem.* 9 (1999) 249.
- [76] Yu.K. Gun'ko, S.D. Elliott, P.B. Hitchcock, M.F. Lappert, *J. Chem. Soc. Dalton Trans.* 2002, in press.
- [77] K. Yunlu, P.S. Gradeff, N. Edelstein, W. Kot, G. Shalimoff, W.E. Streib, B.A. Vaartstra, K.G. Caulton, *Inorg. Chem.* 30 (1991) 2317.